

Making Light Work Lighter

General Photonics

C O R P O R A T I O N

PCD – 003

Fiber-Optic Polarization Scrambler Board

Operation Manual

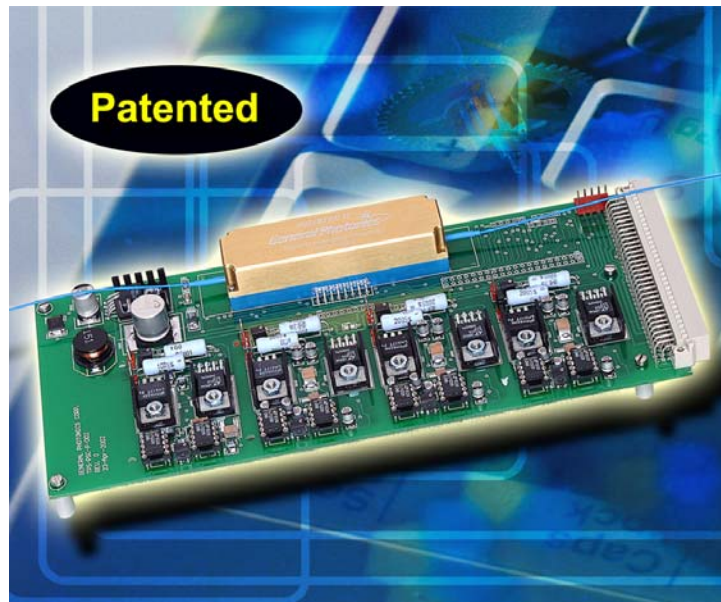

Oct 30, 2002

General Photonics Corp.
5228 Edison Ave.
Chino, CA 91710 USA

Ph: (909) 590-5473
Fax: (909) 902-5536
www.generalphotonics.com

Table of Contents:

Section 1	Specifications	3
Section 2	Overview	4
Section 3	Feature Description	5
	3.1 Optical Features	5
	3.2 Electrical Features	6
	3.3 Environmental Features	7
Section 4	Operation Instruction	8
	4.1 Unpacking	8
	4.2 Getting Started	8
	4.3 Testing and Characterization	9
Appendices		
	Appendix A PCD-003 Scrambling Frequency Distribution	10
	Appendix B PCD-003 Scrambler Test Report	11

Section 1. Specifications:

Physical Features:

Board Dimensions	220 mm (L) × 100 mm (W) × 30 mm (H)
Fiber Input Connector	FC/PC, FC/APC, SC/PC or SC/APC
Fiber Output Connector	FC/PC, FC/APC, SC/PC or SC/APC

Optical Characteristics:

Insertion Loss	< 0.05 dB (without connectors) < 0.6 dB (with connector)
Center Operating Wavelength	1310 nm, 1550 nm, or user specify
Operating Wavelength Range ¹	> 100 nm
Output Degree of Polarization	< 5% ²
Average PMD	< 0.05 ps
Intrinsic PDL	< 0.05 dB
Optical Return Loss	> 65 dB (without connectors)
Optical Power Handling	> 1000 mW
Residual Amplitude Modulation	< ± 0.01 dB
Residual Phase Modulation	< 0.1 π

Electrical Characteristics:

Power Supply	± 12V DC (1A for +12V, 0.1A for -12V) ± 15V DC can also be used
Power Consumption (±12V)	10 W typical
Scrambling Frequencies	Factory set fixed frequencies Distributed between DC to >700 KHz ³

Environmental Characteristics:

Operating Temperature	10 °C to 40 °C
Storage Temperature	-10 °C to 50 °C

Note:

1. Center wavelength ± 50 nm.
2. At 500 Hz detection bandwidth.
3. Measured from a photo detector at PCD-003 output using a spectrum analyzer. A polarizer is placed in front of photodetector to convert polarization modulation to amplitude modulation.

Section 2. Overview:

PCD-003 is a modular polarization scrambler that integrates General Photonics' Award winning PolaRite II polarization controller and controlling electronic circuits on a printed circuit board, as shown in Figure 1. PCD-003 employs continuous fiber construction that results in extremely low optical insertion loss, polarization dependent loss, and polarization mode dispersion. PCD-003 is an ideal tool for optical measurement, device characterization, network conditioning, and other polarization related applications.

PCD-003 consists of a four-axis electromechanical polarization controller and driving circuits that generate control signals at different frequencies. The operation of PCD-003 can be described as a multi-stage birefringent modulator in cascading. All the birefringent modulators operate at different modulation frequencies that randomize the output polarization state. The theoretical background information on scrambler operation and the use of PolaRite II can be found in General Photonics' world wide website: <http://www.generalphotonics.com>. The driving voltage for each axis has been preset for minimum degree of polarization (DOP). External DC power supplies are needed to operate the module.

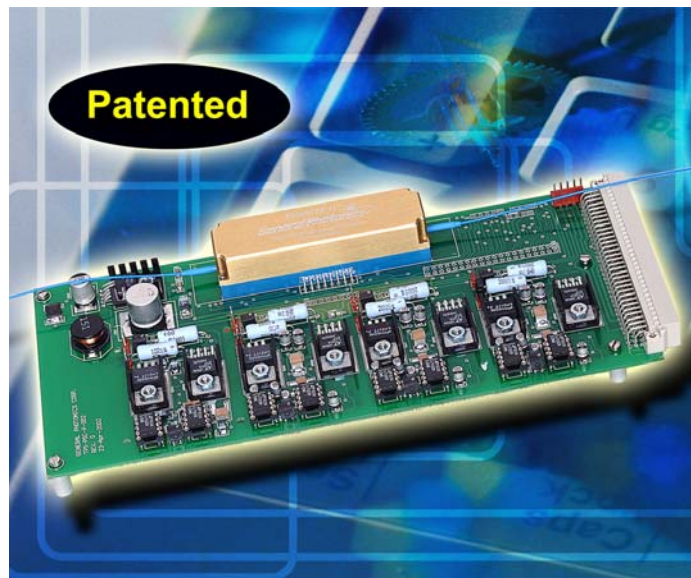

Figure 1. PCD-003 polarization scrambler module.

Section 3. Feature Descriptions:

Warning:

PCD-003 module is not user serviceable.

Avoid touching the heat sink because the temperature on the heat sink may exceed 60°C in normal operation.

3.1 Optical Features:

PCD-003 module has two fiber pigtailed, one for the input and the other for the output. The input and output fiber pigtailed are interchangeable unless user specifies special connector combinations for the input/output fiber pigtailed.

Fiber connectors can either be FC/PC, SC/PC, or FC/APC per customer's specifications.

Before each connection, fiber connectors should be cleaned using industry standard fiber connector cleaning methods.

Fiber pigtailed should be handled carefully. Excessive force on fiber pigtailed may degrade scrambler performance or damage the device.

3.2 Electrical Features:

PCD-003 is designed as an equipment plug-in module. It can be also used separately for laboratory research and experiment. In this case, a $\pm 12\text{V}/1\text{A}$ DC dual output supply is required to operate the scrambler. A $\pm 15\text{V}$ DC/1A dual output power supply can be also used with slightly more heat dissipation. The external power supply needs to be connected to a 5-pin connector jumper block JPOW near upper right hand corner with Polarite II controller on top, as shown in Figure 2 and 3. A color-coded power supply jump cable is supplied for convenient DC power connection. The pin connection scheme is also shown in Figure 3.

The scrambling frequencies are set at the factory that is not user adjustable. Four driving frequencies produce a large sum of mixing frequencies distributed over large spectrum range. The distribution of the driving frequencies and their mixing products are shown in Appendix A.

There are multiple jumpers set at factory for testing and tuning purpose. User should not remove these jumpers unless authorized by the manufacturer.

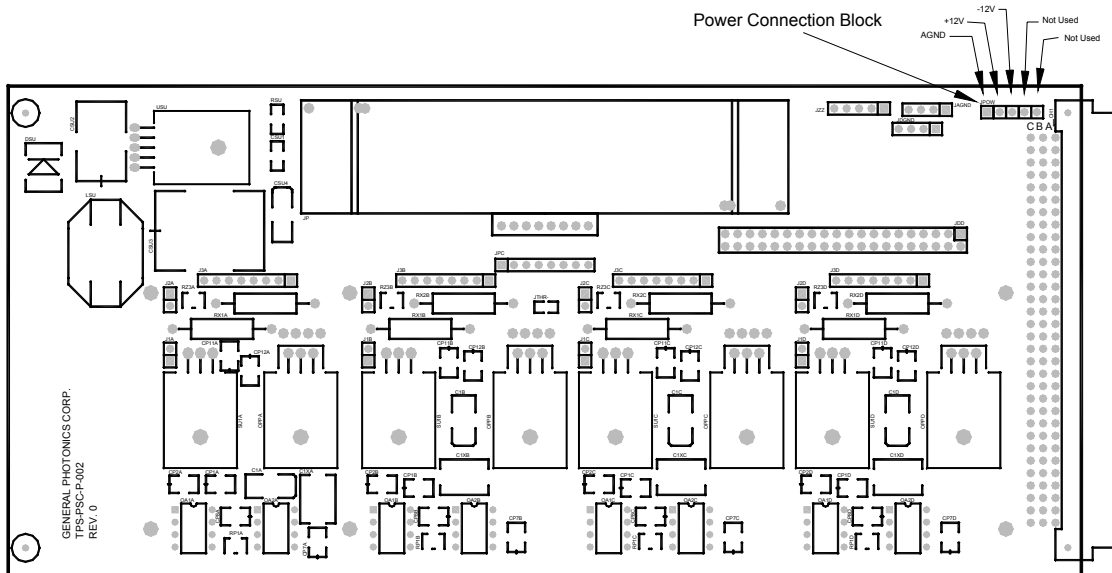

Figure 2. Circuit board layout showing the DC power connector location.

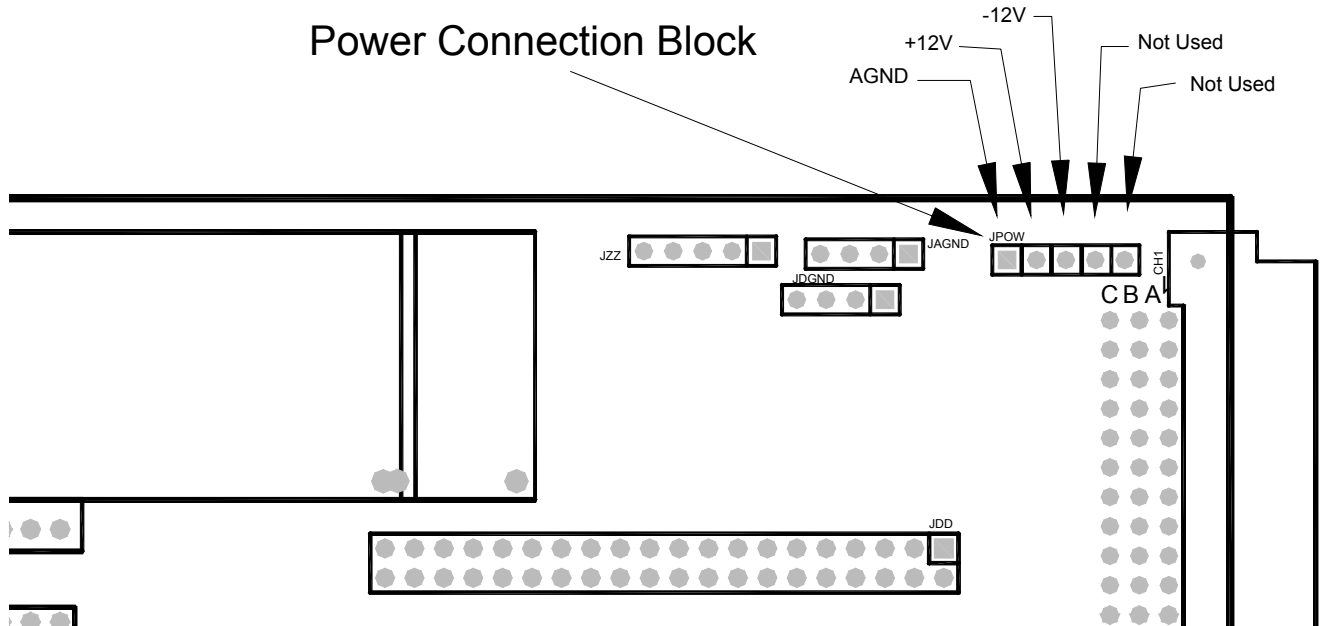

Figure 3. Magnified power connector area where AGND (analog ground) and ± 12 V are for scrambler board operation. Other two leads are not used for this module board.

3.3 Environment Features:

PCD-003 is designed for indoor use in an office or laboratory environment. If PCD-003 is placed inside an enclosure, forced-air cooling is strongly recommended for stable DOP performance.

The recommended operation temperature range is 10 - 40°C. Outside this temperature range, the DOP will increase gradually as the temperature difference (referenced to 25°C) increases.

For best performance, a warm up period is recommended before the operation. The warm-up time is typically 20-30 minutes. During the warm-up time, the module is operational and the DOP will be less than 10%.

Section 4. Operation Instruction:

To operate PCD-003 as an individual laboratory instrument, electrical and optical connections are required during setting up. Follow the safety precautions when make electrical and optical connections.

Warning:

Never look at the fiber connector against the light exit direction when light source is connected. THE OUTPUT LIGHT FROM PCD-003-R1 MODULE MAY BE HARMFUL TO HUMAN EYES.

4.1 Unpacking

Great care must be taken when unpacking PCD-003 module from its original shipment package.

The electronic circuit is sensitive to static discharge.

Inspect the module to see if any component becomes loose or disconnected during shipment.

Avoid applying any force to two optical fiber pigtailed (blue color) and do not let any free-drop of fiber connectors occur at any time.

4.2 Getting Started

Follow the steps below to operate PCD-003 in a laboratory environment.

Set the power supply to the correct voltage and connect the cable according to Figure 3. The corresponding color codes are

Black:	GND (± 12 V ground)
White:	+12 V
Gray:	-12 V

Turn off the power supply before plugging the cable to power jumper connector JPOW shown in Figure 2 and 3. The cable connector is unidirectional. Care must be taken to avoid damaging the fiber pigtailed nearby.

Turn on the power supply and allow the module to warm up. The warm-up time is about 20 minutes. PCD-003 can be used during warm-up, but the DOP will not be optimized (DOP < 10% during warm-up).

After warm-up, the well-adjusted electronics will control PCD-003 to achieve optimum performance regardless of input state of polarization (SOP).

Note: After module warm-up, the heat sink temperature can reach over 60°C at normal operation conditions. Avoid skin contact to the heat sink on the module.

4.3 Testing and Characterization:

PCD-003-R1 can be serviced only by manufacturer authorized personnel. No user serviceable components in this module.

User can test the performance of PCD-003 with available polarization analysis instruments or other established methods. Note that the DOP specification for PCD-003 is measured at a detector bandwidth of 500 Hz. For high bandwidth detection systems, the DOP can be obtained by averaging data samples within the desired time frame using appropriate sampling systems or instruments.

DOP at polarization scrambler output can be calculated from a simple intensity measurement. In this measurement, a polarizer is placed between the scrambler output fiber and the photodetector with a known detection bandwidth. The maximum and minimum intensities I_{\max} and I_{\min} are then measured from the detector output. The DOP in the measurement bandwidth can be calculated from

$$\text{DOP} = \frac{I_{\max} - I_{\min}}{I_{\max} + I_{\min}} \times 100\%$$

Note that I_{\max} and I_{\min} are measured within the desired bandwidth. Different detector bandwidth setting will have different I_{\max} and I_{\min} values.

Appendix A: PCD-003 Scrambling Frequency Distribution

The multi-stage birefringence modulation results in a polarization modulation at a wide spectrum of beating frequencies. The frequency distribution for a typical PCD-003 module is shown in Figure A1. The data was measured by passing light through a polarizer to a photo detector, and detector output was feed to an electrical spectrum analyzer. The frequency distribution is quite uniform to 700 KHz range and gradually decrease in strength until 2 MHz. The frequency distribution may differ slightly in different modules due to different frequency settings and input polarization state.

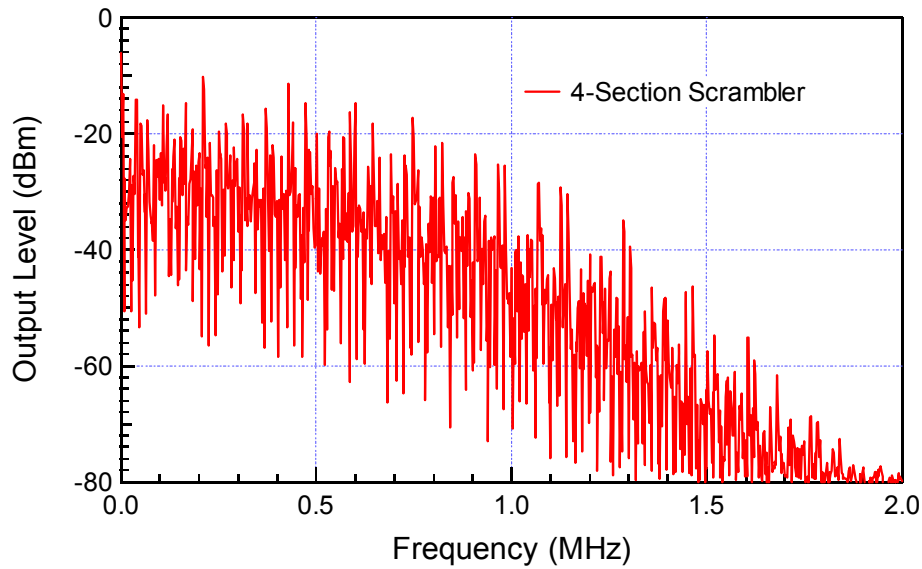

Figure A1. PCD-003 scrambling frequency distribution measured through a polarizer between 0 ~ 2 MHz.

Appendix B: PCD-003 Scrambler Test Report

Model Name: PCD-003

Serial No.: _____

Test Set-up:

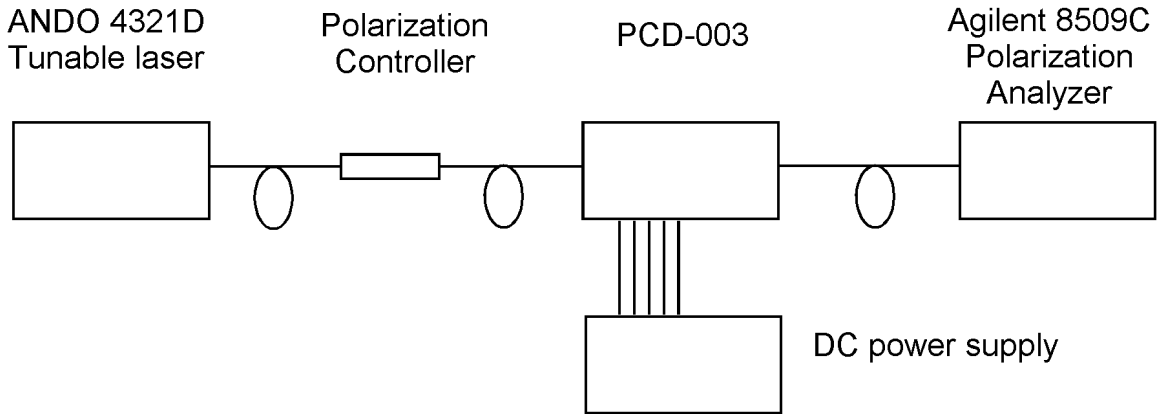

Test Conditions:

Laser wavelength _____ nm
Ambient Temperature _____ °C
Total Burn-in Time _____ Hours
8509C Settings Display Update: 20 Points
System Average: On

Test Results:

Output Degree of Polarization (DOP) ≤ _____% (at 23°C)
Output DOP ≤ _____% (within 10-40°C)
Warm-up time 30 minutes
Insertion loss with connectors _____ dB

Tested by: _____ Date: _____